

# BOOSTER FILLPATTERN MONITOR

F. Falkenstern, J. Kuszynski, G. Rehm  
Helmholtz-Zentrum Berlin, Germany

## Abstract

The "Booster Fillpattern Monitor" is used to measure currents in each individual electron bunch in the booster of the BESSY II machine.

The booster with its circumference of 96 meters has space for max. 160 electron bunches. The distance between the electron bunches of 60 cm (96 m / 160) is determined by the RF Master Clock  $\sim 499,627$  MHz. In practice, fill patterns of a one to five equally spaced bunches are in use.

The fill pattern monitor digitizes electrical pulses generated from a strip line using a broadband ADC. The sampling frequency is selected as an integer fraction of the bunching frequency, acquiring the full fill pattern over a number of turns.

Experiments performed at BESSY II demonstrate the performance of the setup and will be discussed.

## INTRODUCTION

The BESSY II electron storage ring (SR) is a third-generation light source operating at an energy of 1.7 GeV with a stored current of 300 mA in the top-up mode [1]. The top-up injection in the SR allows almost constant synchrotron light for the users at the beamlines.

For injection into the BESSY II SR a full energy fast cycling booster synchrotron is used. Injection at full energy offers a lot of advantages for a high brilliance synchrotron radiation. It ensures a shot filling time, ion trapping etc. [2].

In the SR, electrons might be stored in any pattern consisting of up to 400 buckets (Fig 1).

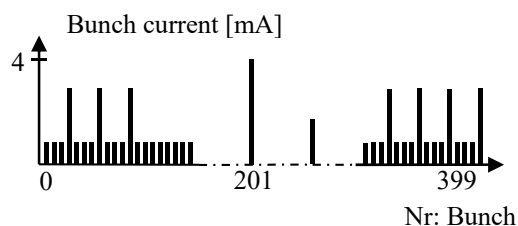

Figure 1: The typical fillpattern at storage ring BESSY II.

The injection of electrons in these buckets is managed from the TopUp engine [3]. It is possible to fill one to five buckets in the SR simultaneously. For this, the information from the fill pattern monitor (BunchView) in the SR is used [4].

The TopUp engine analyses this information and starts injection in the SR for filling the lost electrons in the emptiest bunches.

## REQUIREMENTS

For the permanent optimization of the storage ring and the safe operation of the BESSYII machine, the reliably working injection into the storage ring is of great importance. In case of failure of injection system (Linac, Booster etc.), the beam in the storage ring is in decay mode. During the lifetime of about 8 hours, only half of the electrons remain in the storage ring after 8 hours. Most users at beamlines need constant synchrotron light (constant current in the SR) for their experiments. Therefore, the demands for diagnostics in this area have grown significantly. The booster fill pattern monitor was developed because of these increased demands on diagnostic capabilities.

## REQUIREMENTS TO THE SYSTEM

The bunch resolved measurements have a large demand on the bandwidth of the RF signal, which makes acquisition and digitization difficult. Suppressing the signal noise with narrow analog filters is not possible. Improving the signal-to-noise ratio is then only possible by averaging of sampling data with digital processing. This requires many sample points from the analog (real) beam signals. For the bunch signals, which are repeated every turn, like the signals in the storage ring, it is mostly possible. In the booster, the circulated bunches are repeated during the booster period, but the induced bunch signal can vary a lot because of the acceleration of the electron buckets. Thus, averaging is not possible over many revolutions.

The second requirement is a sophisticated synchronization. The system needs a low jitter sample clock that is derived from the master clock (MC), revolution trigger and the start trigger of the booster. The measurement system can trigger internally (on the bunch signal) or externally on the start signal. While in operation it is mostly triggered by the external booster start trigger.

The third demand is the memory requirement of samples with high sample rate. It takes 35 ms to accelerate the electrons in the booster to the point of extraction. With the high sampling rate, it requires many megabytes of FIFO memory. As the FPGA card only allows a small FIFO memory, the external RAM memory would have to be declared as FIFO.

## SETUP

The measuring system generates a current filling pattern in the booster every second. The external 1 Hz trigger starts recording data. The bunch signals (Fig. 2) are generated by a set of striplines (in the vacuum tube) and combined with the RF combiner (Fig 3).

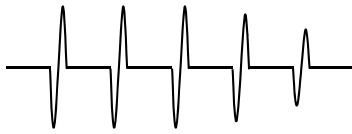

Figure 2: The five pulses induced from five bunches of electrons in the booster.

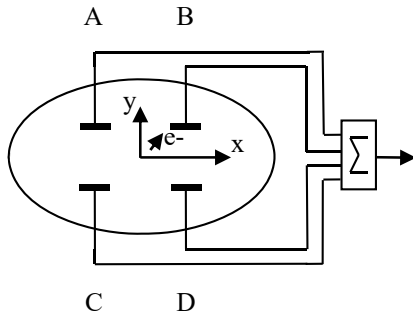

Figure 3: The bunch signals from the set of four striplines (A, B, C, D) in the booster are summed together.

The sum bunch signal (A+B+C+D) of this set of striplines is proportional to the bunch current in the booster. The signal is filtered, amplified, split and fed to two inputs of the fast broadband 14-bit ADC card.

The simplified block diagram (Fig. 4) shows the structure of the system.

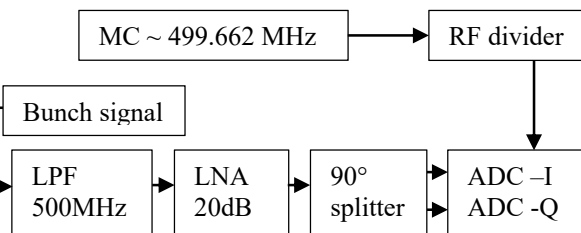

Figure 4: The block diagram with hardware of booster fillpattern monitors.

The digitization is synchronous to the integer fraction on the master clock (MC) of the BESSY machine of ~499.627 MHz.

The measurement of the bunch current is based on the IQ principle. The first ADC samples the I signal (amplitude) and the second converter samples the Q signal (phase) shifted by 90°. The sampling time of about 40 ns captures the whole time from the injection into the booster from the linac to the extraction from the booster into the storage ring. For averaging, the last sample values (100 turns) are taken just before the extraction. This im-

proves the amplitude resolution of the acquired signals for each individual bunch. Calculating the vector amplitude as  $A = \sqrt{I^2 + Q^2}$ , can be simplified to  $A=I$ , for  $I \gg Q$ . The information about the phase is used for testing purposes. The large changes in the phase can be an indication of booster or Linac instability.

The values of amplitude and phase obtained in this way are entered into the EPICS PVs (Fig. 5).

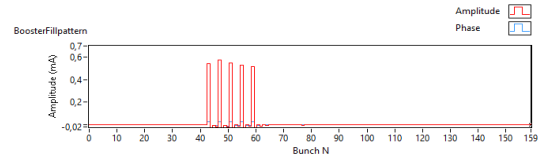

Figure 5: Fillpattern with five filled bunches in the booster ring of max 160 buckets.

### CALIBRATION

For the normalization of the bunch current, it utilizes information from the beam current monitor in the booster [5]. The ADC signal noise of many empty bunches must be set to zero. The result, after one-time calibration, is shown in Fig. 6. The sum current of all bunches in the booster is then equal to the booster beam current.

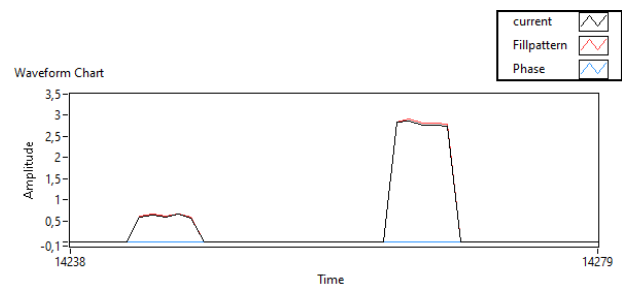

Figure 6: The correlation of current from one and five bunches in the booster (Fillpattern) to the current from the beam current monitor. The phase signal for the stable bunches in this time slot are then near zero.

The fill pattern during extraction (amplitude and phase) is stored in the individual PVs. The detection of the extraction is based on the comparison of the sampled data between two-time intervals in the 33 ms (14 ns \* 2,300 M) and 38 ms (14 ns \* 2,600 M) range. After extraction from the booster (35 ms) the bunch current (amplitude and phase) in the range of 38 ms is always zero. The sample frequency is about ~71.4 MHz (MC/7).

The larger sample data from ADCs are reduced by sampling every 1000<sup>th</sup> value and stored in PVs (Fig. 7).

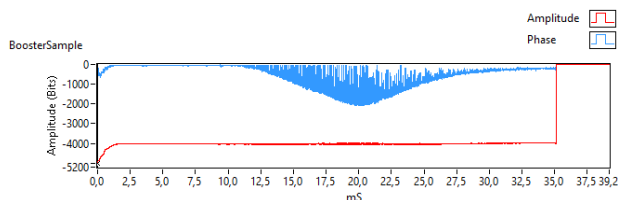

Figure 7: The data compressed of 2.8k for the amplitude and phase during accelerated and extracted electron buckets from the booster.

### BUNCH NUMBERING

The bunch-number in the booster can be adapted to the number of bunches in the storage ring only within limits. The reason is, that the circumference of the storage ring is 2.5 times larger than that of the booster. Thus, the first 160 bunch-numbers in the storage ring will be equal to the number in the booster. The position of electron packets in the storage ring between 160 and 399 will be reachable after one or one and a half revolutions in the booster as shown in Fig. 8.

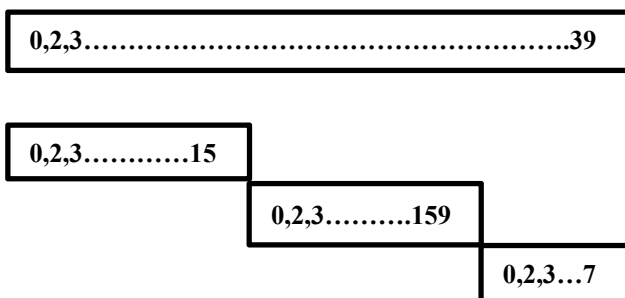

Figure 8: Number of electron bunches in the SR and the booster.

### HARDWARE AND SOFTWARE

The hardware of the measurement system consists of a "Frontend Booster" module (RF amplifier and RF splitter) and a PXI crate with (RF divider1/7, PXIe controller, ADC/FPGA card). These plug-in units have found their place in the "RACK 6" (Fig. 9).

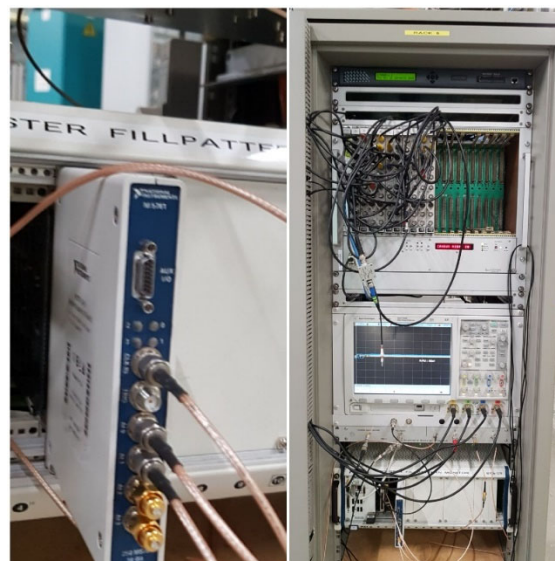

Figure 9: The Hardware of the booster fillpattern monitor is located under the scope in the RACK 6.

The PXIe controller with LabVIEW drives the ADC and FPGA card. The program calculates the all-bunch currents in the booster and update the corresponding EPICS data.

### SUMMARY

The possibilities of advanced diagnostics like fill pattern monitor in the booster allows the improvement of injection at BESSYII. The system can be used for different physical studies.

The whole process of acceleration of electron bunches over time until extraction from the booster is stored for each individual bunch with the amplitude and phase. Thus, all deviations from normal acceleration processes are quickly detected and localized. The data can be arbitrarily compressed and stored in EPICS variables.

### REFERENCES

- [1] P. Kuske *et al.*, "Preparations of BESSY for Top Up Operation", in *Proc. EPAC'08*, Genoa, Italy, Jun. 2008, paper WEPC037, pp. 2067-2069.
- [2] M. Abo-Bakr *et al.*, "The BESSY II\* Booster Synchrotron", in *Proc. EPAC'96*, Sitges, Spain, paper TUP007G, pp. 527-529.
- [3] T. Birke *et al.*, "Comprehensive Fill Pattern Control Engine: Key to Top-Up Operation Quality", in *Proc. ICALEPCS'15*, Melbourne, Australia, Oct. 2015, pp. 18-21. doi:10.18429/JACoW-ICALEPCS2015-MOC3001
- [4] F. Falkenstern *et al.*, "BunchView", in *Proc. DIPAC'09*, Basel, Switzerland, May 2009, paper MOPD40, pp. 128-130.
- [5] J. Kuszynski *et al.*, "Measuring beam intensity and lifetime in BESSY II", in *Proc. DIPAC'99*, Chester, UK, May 1999, paper PT03, pp. 159-161.