

PRELIMINARY EVALUATION OF THE MTCA.4 BPM ELECTRONICS PROTOTYPE FOR THE PETRA IV PROJECT

P. Leban, M. Cargnelutti, A. Bardorfer, M. Oblak, B. Repic, L. Bogataj, P. Paglovec
 Instrumentation Technologies (I-Tech), Slovenia

G.Kube, F.Schmidt-Föhre, K.Wittenburg, Deutsches Elektronen-Synchrotron DESY, Germany

Abstract

Within the PETRA IV project at DESY, the synchrotron radiation source PETRA III will be upgraded into a low-emittance source. The small beam emittance and reduced beam size imply stringent requirements on the machine stability. To meet the requirements on position measurement and orbit stability, a high-resolution BPM system will be installed in the new machine, with about 800 BPMs and MTCA.4-based readout electronics.

In the TDR phase of the project, I-Tech and DESY are cooperating on the realization of a BPM prototype that will demonstrate the feasibility of reaching the PETRA IV requirements. Several analog, digital and SW parts are taken from the Libera Brilliance+ instrument and are reused in the MTCA.4 BPM prototype, with some innovations. One of them is the separation of the RF switch matrix used for long-term stabilization: placing it near the BPM enables also the long RF cables to be stabilized. An 8 channel RTM board, able to acquire signals from two BPMs was developed and is also tested.

This paper presents an overview of the BPM electronics prototype and the promising test results achieved in the Instrumentation Technologies' laboratory with the first boards produced.

PERFORMANCE REQUIREMENTS

The PETRA IV performance requirements for the BPM electronics are presented in Table 1.

Table 1: Performance Requirements for the PETRA IV BPM Electronics

Parameter	Requirement
Resolution on single bunch/turn	< 20 μm RMS (0.5 mA)
Resolution on closed orbit	< 200 nm RMS (at 200 mA in 1600 bunches, 300 Hz bandwidth)
Beam current dependence	$\pm 2 \mu\text{m}$ (0 to -60 dBm range)
Long-term stability at room temperature (25°C)	< 1 μm (6 days, ± 1 K)
FOFB latency	≤ 3 turns

PROTOTYPE DESCRIPTION

The PETRA IV project requirements [1] for the BPM electronics performance could not be met with the

commercially available Libera instrumentation entirely. A characteristic of the machine are the long RF cable paths between the BPM and the BPM electronics which can extend over 150 metres, up to 200 metres. The compensation mechanism in the Libera Brilliance+ instrument is not capable to compensate the disturbances along the cables which makes position readout sensitive to environmental and mechanical factors. To fulfill the 1 μm long-term stability over 6 days ($\Delta T = \pm 1$ K), the RF cables must be compensated well.

Another project-specific requirement is that the BPM electronics hardware should be based on the MTCA.4 standard, with a combination of modules provided either by DESY, by commercial suppliers or developed specifically. In the time frame of the TDR phase of the project, I-Tech developed the RTM module which contains the RF front-end, analog signal conditioning components and the A/D converters. The module connects to the DESY's AMC module [2]. In each of the machine cells, all the BPM electronics, including the Fast-Orbit-Feedback (FOFB) and timing cards, are foreseen to be installed in a single 12-slot chassis. Due to space constraints, a high density of RF channels per BPM module was preferred. Taking into account other constraints, such as power consumption and cooling capabilities, the final RTM design includes 8 RF channels with standard SMA-F connectors and 2 additional RJ-45 connectors. The A/D converters are dual-channel 125 MHz/16 bit and are driven by the clock provided through the HW or SW PLL on-board the RTM module. The reference clock is locked to the turn-by-turn clock of PETRA IV provided by the timing system.

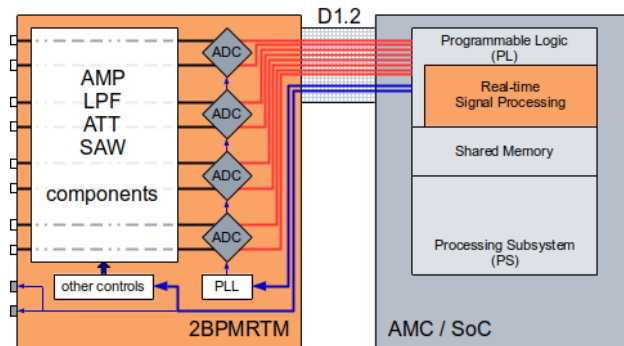

Figure 1: RTM and AMC modules used for the prototype system.

A general-purpose AMC module was used for the development phase and it utilizes a high-performance Zynq Ultrascale+ (ZUP) System-on-Chip (SoC) with 1 GB shared memory for the programmable logic (PL). According to the architecture, only the PL of the SoC is

Content from this work may be used under the terms of the CC BY 4.0 licence (© 2022). Any distribution of this work must maintain attribution to the author(s), title of the work, publisher, and DOI

used for the real-time signal processing while the processing subsystem part is only used to manage the module's housekeeping. The RTM and AMC modules are presented in Fig. 1.

STABILIZATION TECHNIQUE

The cross-bar switch was implemented in the first Libera instrument generations (Electron, Brilliance) back in 2005 and has been in use in various synchrotron machines since then. By switching, in combination with properly supported software calculations, the amplitude readings were compensated to ensure few tens of nanometers position drift over several hours or days. Since the cross-bar switches were located in the BPM module, only the RF signal path through the BPM module was compensated while the RF cables connecting the BPM with the electronics were not compensated. While majority of the synchrotron machines do not suffer from disturbances along their few ten meters of RF cable lengths, the PETRA IV project is going to be more challenging. The RF cables may have to be as long as 200 metres going through various locations with their micro-climate conditions.

After a brief brainstorming with the PETRA III Beam Diagnostics group, an idea came to implement a stand-alone module which contains the cross-bar switches with a minimum set of other components. The module should be installed in the tunnel as close to the BPM as reasonably possible and minimize the non-compensated RF cable path (Fig. 2). With such approach, the long RF cables become part of the RF signal path which is compensated by the signal conditioning algorithms in the BPM electronics. The module is powered and controlled from the RTM module through a Cat.7 Ethernet cable [3].

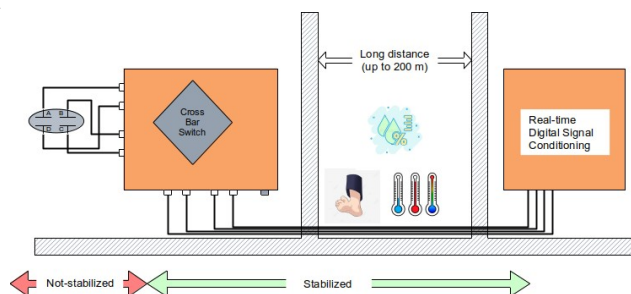

Figure 2: The module with a cross-bar switch is installed inside the tunnel. The signal conditioning algorithms in the BPM electronics compensate the disturbances along the long RF cables.

SIGNAL PROCESSING AND DATA READOUT

The analog signals are sampled by the A/D converters on the RTM module and are transferred to the AMC module over the Zone 3 connector class D1.2 interface. The raw ADC samples with approximately 8 ns time resolution are processed by several FPGA blocks that apply the bitmasks, fine-tune the time delay and specify the processing type for the turn-by-turn and multi-bunch

turn-by-turn data. The buffered data is stored in the SoC's shared memory and provided to the main CPU module over the PCIe bus. The streaming data intended for fast and slow monitorings is transferred through the PCIe as well. The CPU module runs the Libera BASE software framework which supports various hardware module types and hosts the specific applications (e.g., BPM application). The application communicates with multiple AMC modules within the MTCA.4 chassis and provides a generic user interface for data readout and parameter control. The prototype version already supports various clients but generic command-line interface ("libera-ireg") will be used for testing at PETRA III. DOOCS is planned for the PETRA IV machine [4]. Fig. 3 shows the processing blocks in the AMC and CPU modules.

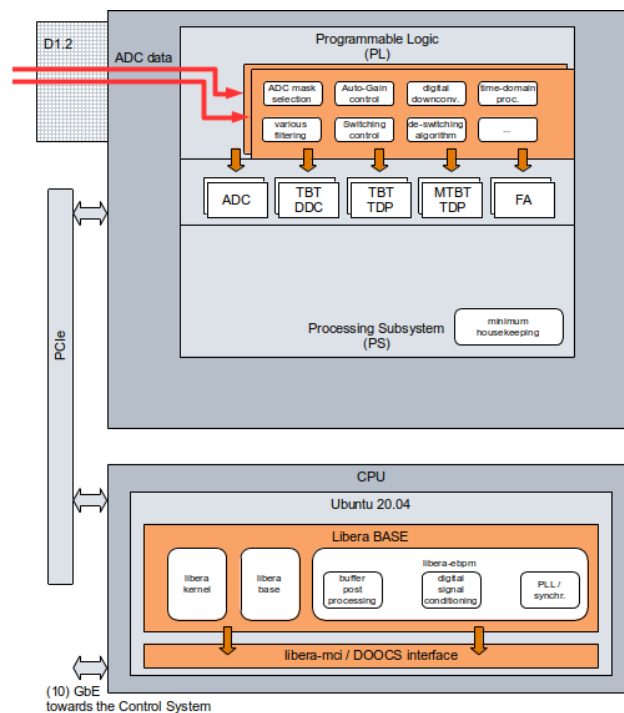

Figure 3: Signal processing, data buffers and software framework in the AMC and the CPU modules.

PROTOTYPE EVALUATION

The core parts of the Libera Brilliance+ FPGA processing were reused and transferred to the MTCA.4 prototype. This enabled quick and effective performance evaluations that were required to confirm the hardware conforms with the project requirements. Before the first production run of the RTM modules, the commercial name was set to "2BPMRTM".

2BPMRTM Module Evaluation

A subset of tests presented in this paper includes verifications of the input signal range, input noise density and crosstalk between channels.

The maximum input signal power is +4 dBm CW at nominal frequency. The RF chains are equipped with a 31 dB programmable attenuator. The input noise density

was measured and calculated for maximum and minimum attenuation values (31 dB and 0 dB). Results are presented in Table 2.

Table 2: Input Noise Density

Channel	Input noise density
Maximum attenuation (31 dB)	-144 dBm/Hz
Minimum attenuation (0 dB)	-169 dBm/Hz

The crosstalk between the channels is presented in Table 3. The worst crosstalk measured was -76 dB between channels B and C. The 2BPMRTM module supports 2 BPMs (8 channels). The maximum crosstalk between the 2 BPMs was measured -95 dB (BPM1 channel D, BPM2 channel A).

Table 3: Crosstalk Between the Channels on a Single BPM

	A	B	C	D
A	/	-82 dB	-88 dB	-97 dB
B	-80 dB	/	-86 dB	-95 dB
C	-90 dB	-76 dB	/	-78 dB
D	-95 dB	-94 dB	-81 dB	/

The 2BPMRTM module is shown in Fig. 4. The front-panel contains 8 SMA-F and 2 RJ-45 interfaces.



Figure 4: 2BPMRTM prototype.

Results in Laboratory Setup

The measurement performance was evaluated also using the external switching module (official name: Libera XBS FE) according to the standard testing procedure used for the Libera Brilliance+. Various cable lengths between the 2BPMRTM module and Libera XBS FE were tested ranging from few meters up to 200 meters. The monitor constant used in all measurements was $K_x = K_y = 10$ mm.

The short-term measurement performance was evaluated in the laboratory environment with quasi-stable temperature conditions. The test setup is used for production tests of the Libera instrumentation and uses calibrated generators. RMS values of the turn-by-turn and 10 kHz data were evaluated at input signal power from 0 dBm down to -60 dBm, CW. Figure 5 shows the results for a single plane and for signal range down to -50 dBm. The bandwidth of the turn-by-turn data is DC to ~45 kHz, the 10 kHz data has a bandwidth DC to 2 kHz.

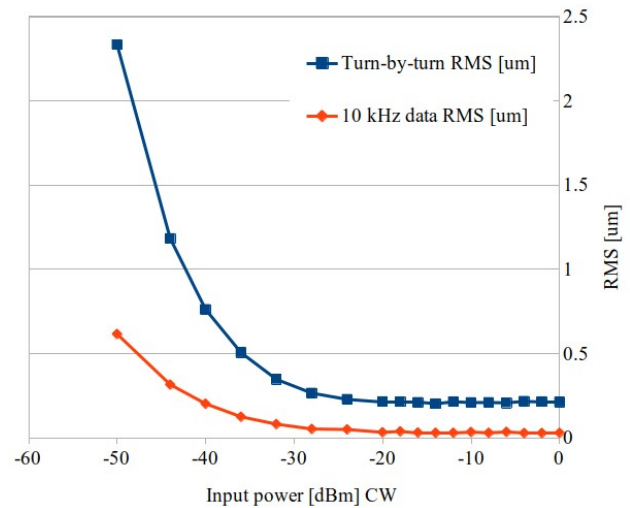

Figure 5: The turn-by-turn RMS and 10 kHz data RMS values are < 1 μ m down to -40 dBm CW input signal.

The linearity (beam-current dependence) was measured under same setup as the short-term performance. Figure 6 shows the beam current dependence characteristics for centered and off-centered (~800 μ m) beam conditions. While the centered conditions did not show any obvious position offset, there was a slight offset observed for off-centered conditions for the input power levels where the programmable attenuators were already open completely.

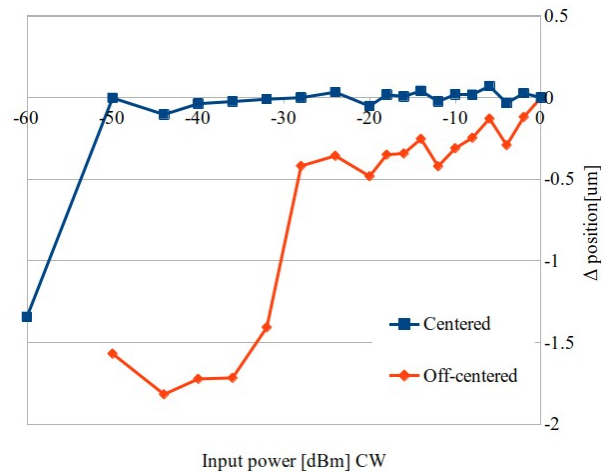

Figure 6: Beam current dependence characteristics.

Crosstalk was measured with the combination of the 2BPMRTM module and Libera XBS FE with a simulated single bunch. Results are presented in Table 4.

Table 4: Crosstalk Between the Channels of the 2BPMRTM Module and Libera XBS FE, Single Pulse

	A	B	C	D
A	/	-55 dB	-56 dB	-57 dB
B	-57 dB	/	-57 dB	-57 dB
C	-56 dB	-57 dB	/	-57 dB
D	-56 dB	-56 dB	-56 dB	/

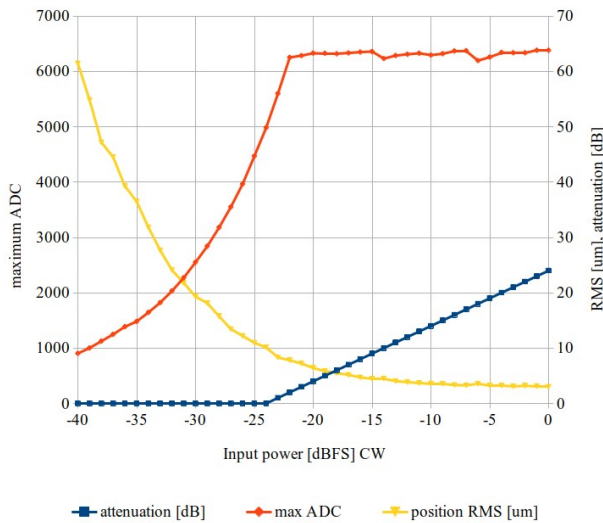

Figure 7: Measurement performance with simulated single bunch.

The single bunch was simulated by an external generator. The pulse width was approximately 1 ns. The required RMS (20 μm) is guaranteed for the input power 0 to -30 dBFS (Fig. 7). The corresponding ADC count level at -30 dBFS is approximately 2500 out of 32768 (full scale).

For the temperature drift evaluation, the whole system was placed in a temperature chamber: RF generator, MTCA.4 chassis, Libera XBS FE and 4x 22m LMR-195 RF cables. Temperature profile:

- 2 days at 25°C
- 10 hours at 20°C
- 5 hours at 25°C then 10 hours at 30°C
- 5 hours at 25°C then 20°C until end of test

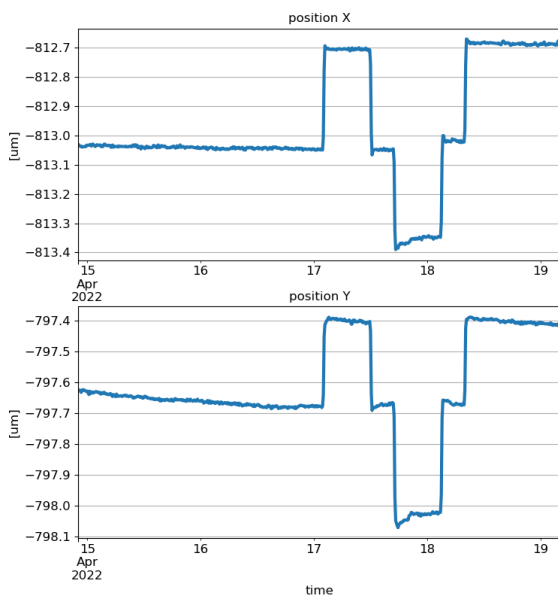

Figure 8: A four-day test in the temperature chamber.

Figure 8 shows the horizontal and vertical position readings from the test. Results are presented in Table 5.

Table 5: Longterm Stability and Temperature Dependence Tests

Property	Value
Position drift at constant temperature	<100 nm peak-to-peak
Position drift under varying temperature	100 nm/K

Results from the laboratory tests confirm the BPM performance meet majority of the requirements from Table 1. Some tests still need to be done [5].

CONCLUSIONS

The prototype BPM system for the PETRA IV project has been under development since December 2020. The first RTM module was developed, produced and tested already in March 2022 showing promising results. In the same time frame, the external switching module prototype was produced and tested with both, the Libera Brilliance+ and the RTM module. Its design and performance were confirmed with beam tests at PETRA III machine and the module had been finalized and produced as a final product in May 2022.

The results achieved with laboratory tests confirm the MTCA-based BPM system conforms with the PETRA IV requirements in all related aspects. Further tests with beam were done at PETRA III as discussed in [5]. Verification of the external switching module's radiation resistance is planned along further beam performance tests.

Main emphasis of the project is now put on the software and FPGA development, supporting also automatic gain control and few other PETRA IV specific features. Later this year, tests at PETRA III with a fully supported MTCA.4 chassis is planned.

REFERENCES

- [1] PETRA IV Conceptual Design Report, <https://bib-pubdb1.desy.de/record/426140/files/DESY-PETRAIV-Conceptual-Design-Report.pdf>
- [2] MicroTCA Technology Lab, https://techlab.desy.de/products/amc/damc_fmc2zup/index_eng.html
- [3] G. Kube *et al.*, "Tests of the New BPM Long Term Drift Stabilization Scheme Based on External Crossbar Switching at PETRA III", in *Proc. IBIC'21*, Pohang, Korea, Sep. 2021, paper MOPP30, pp. 123.
- [4] The Distributed Object-Oriented Control System Framework, <https://doocs-web.desy.de>
- [5] G. Kube *et al.*, "Upgrade of the BPM Long Term Drift Stabilization Scheme Based on External Crossbar Switching at PETRA III", presented at IBIC'22, Krakow, Poland, Sep. 2022, paper WEP08, this conference.