

## ABSTRACT

The Canadian Light Source is a 3rd generation synchrotron which supports 22 operational beamlines. To improve reliability and performance, and to support new diagnostic capabilities, the orbit correction system was upgraded in 2021.

## OVERVIEW

The orbit correction system is responsible for maintaining the orbit of the stored electron beam. This is accomplished by monitoring beam positions using D-tAcq analog to digital converters [1][2], computing deviations in the beam from the ideal location and then distributing setpoints to magnet power supplies, using custom built NIM modules that incorporate PoLabs single board controllers [3], to correct the orbit. The overall hardware layout is depicted in Figure 1.

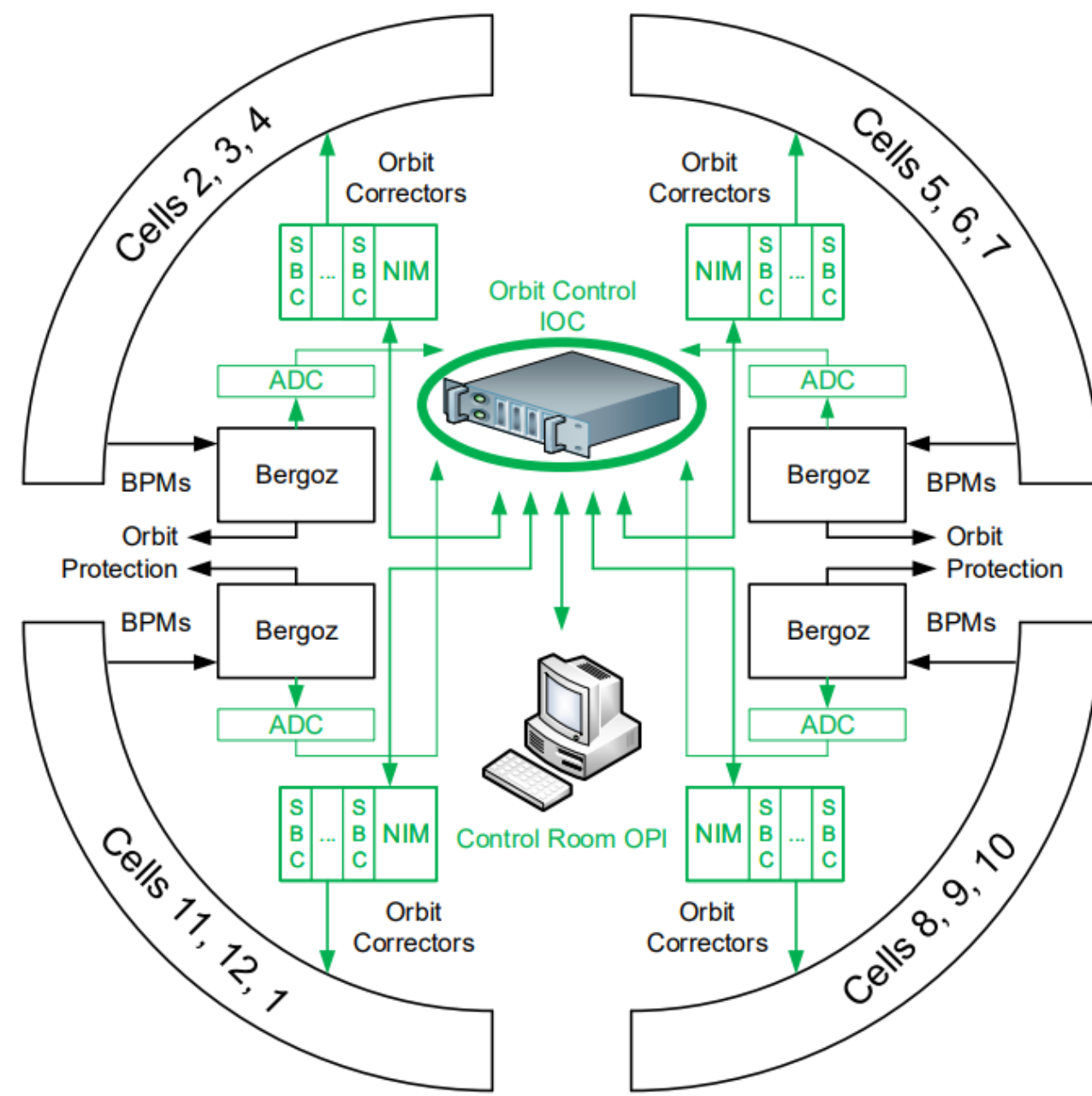

Figure 1: Orbit Correction Hardware

The interface used to monitor this system, shown in Figure 2, supports the following features:

- RMS and standard deviation values for beam positions.
- Visualization of beam positions and magnet setpoints exposed over extended periods of time.
- Dynamic saving and loading of configuration and machine parameters.
- Advanced error handling and system monitoring with real time reporting.
- Sine and square wave signal generation.
- Automated verification of magnet power supply hardware.
- Digital Filtering on beam position inputs and magnet setpoint outputs.

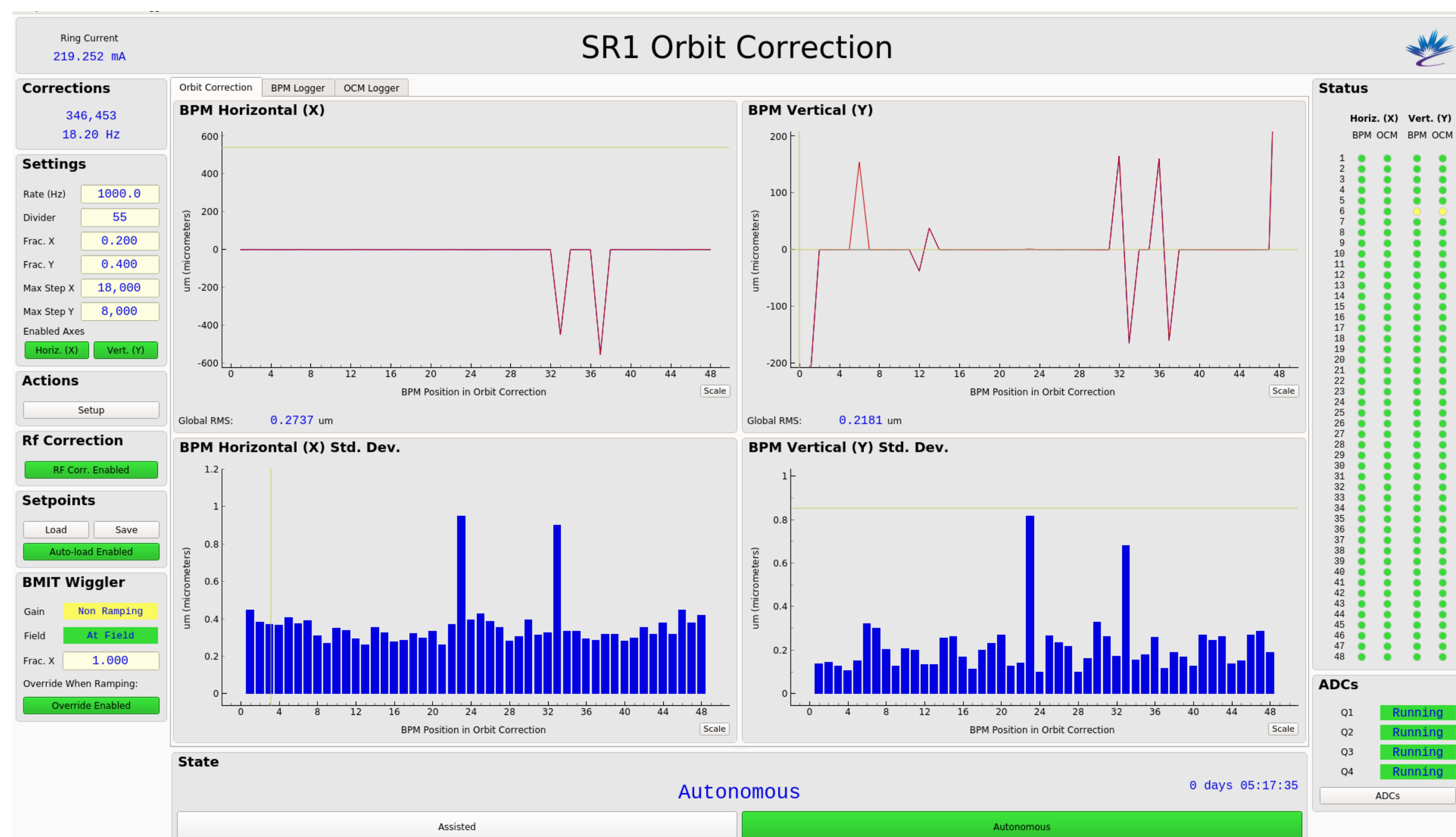

Figure 2: Orbit Correction Interface

## WAVEFORM GENERATION

Waveform signals can be sent to any combination of orbit correctors. This functionality has proven to be beneficial for both commissioning and as a diagnostic tool for analyzing noise issues. By introducing a sine or square wave with selectable frequency, amplitude and offset, the orbit correction system performance can be analyzed as it damps out the injected signal. This allows us to measure the closed loop bandwidth.

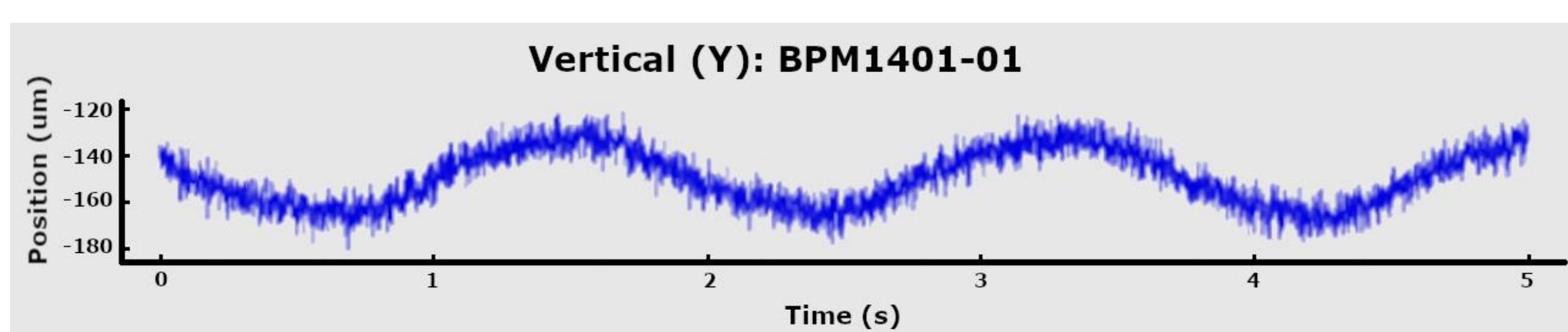

Figure 3: Effect of a sine wave introduced on a vertical orbit corrector.

The sine wave generation, shown in Fig.3, is also used to diagnose noise issues. This is done by moving the electron beam to determine whether the noise seen by a beamline is introduced by this beam motion.

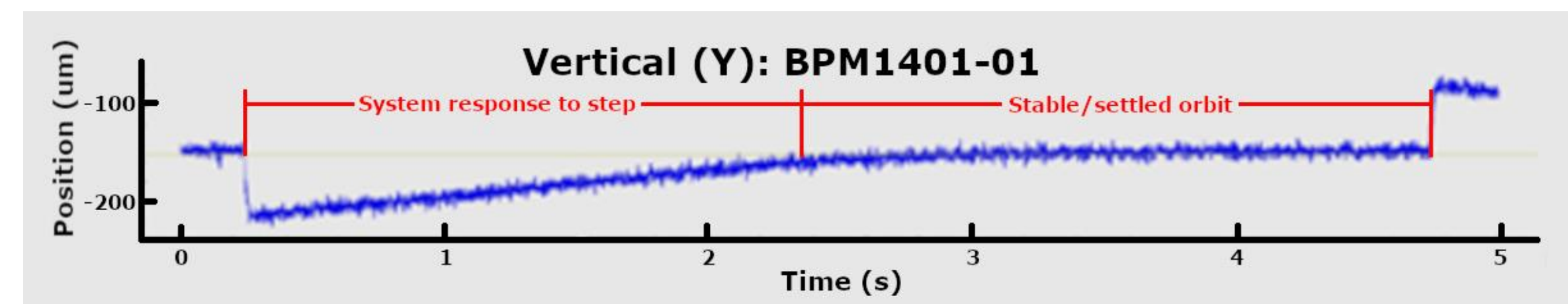

Figure 4: Introduction of a square wave to measure system response.

The square wave generation, shown in Fig 4. can be used to determine the step response of the system.

## REAL-TIME DIAGNOSTICS

The beam position values and orbit corrector setpoints are exposed at a rate of up to 1000 Hz which allows correlation of this information with other machine parameters. Figure 6 shows the effect on the stored beam when ramping the BMIT (Biomedical Imaging and Therapy) superconducting 4.3 Tesla wiggler from zero.

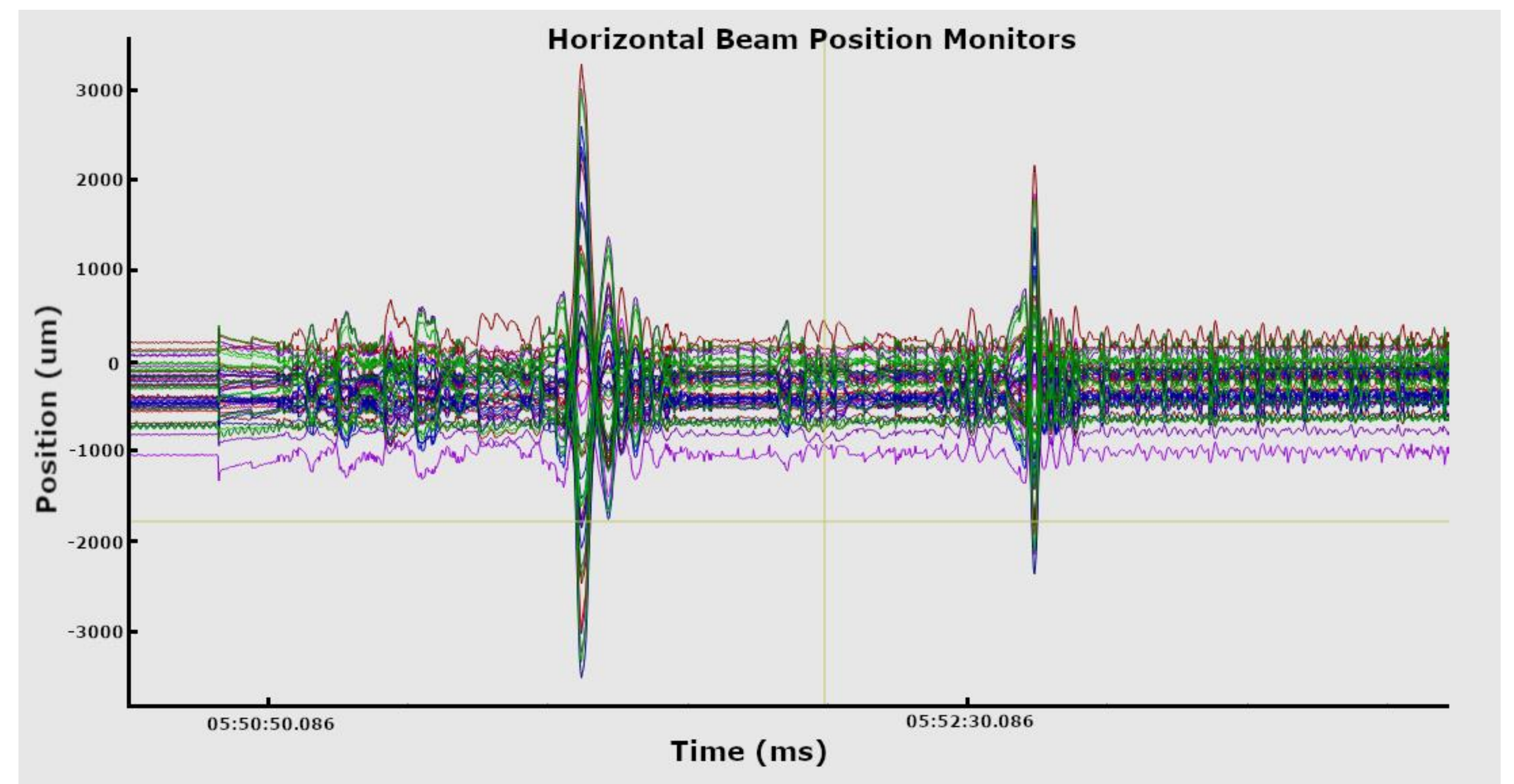

Figure 6: Beam position correlation scatter plots.

Power spectral density and cumulative power spectral density data are exposed for all BPMs. This information quantifies noise in the stored beam as a function of frequency. The interface, shown in Figure 5, allows any combination of BPMs to be selected simultaneously.

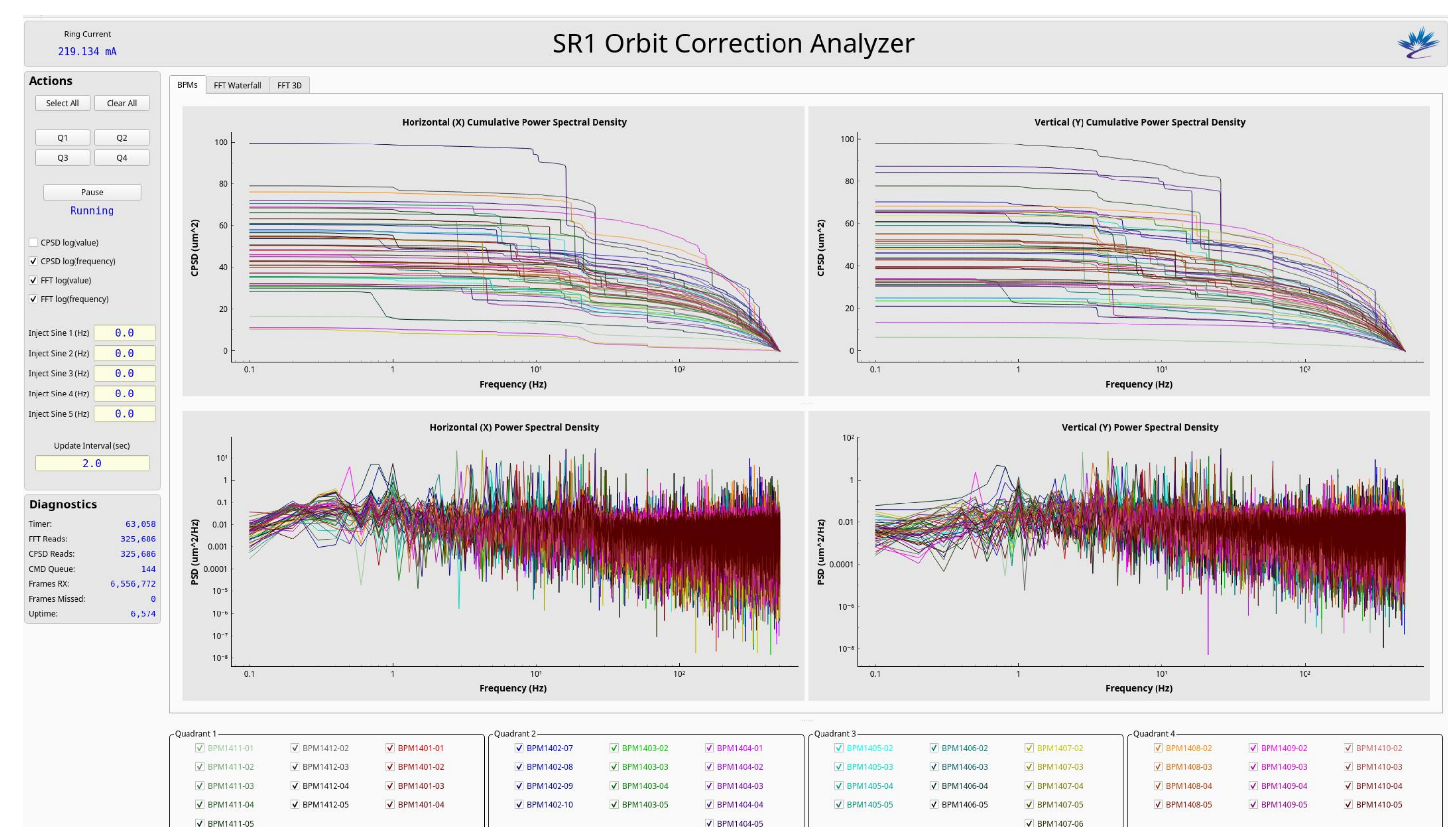

Figure 5: Beam position power spectral density and cumulative power spectral density interface.

## CONCLUSIONS

The upgrade of the orbit correction system has improved reliability and maintainability, and has dramatically increased the diagnostic capabilities available. The extensible architecture supports easy integration of new functionality, providing the foundation for future enhancements.

## REFERENCES

- [1] D-tAcq ACQ435ELF 32 Channel Simultaneous Sampling Digitizer (<https://www.d-tacq.com/acq435elf.shtml>)
- [2] D-tAcq ACQ2106 6 Site ELF Carrier (<https://www.d-tacq.com/acq2106.shtml>)
- [3] PoLabs PoKeys57E Ethernet Computer Numerically Controlled Controller (<https://www.poscope.com/product/pokeys57e/>)